

RA710023 Service Kit for "Below Deck" Compact Motor™

Instructions For Water Trap Retrofit And Lip Seal Replacement



Safety First! Always disconnect power before performing any service or maintenance work on an electric winch.

We recommend replacement of the drive shaft lip seal on your Compact Motor™ every 3 to 5 years, depending on usage, in order to avoid water ingress and ensure a long and trouble-free service life.

Since 2015, below-deck Compact motor units are fitted with a water trap located in the drive shaft housing for enhanced protection against water ingress. These units can be identified by the presence of three drain holes, 5mm in diameter, at the base of the drive shaft housing.

If your motor unit does not have these drain holes, we recommend that you retrofit the water trap when replacing the drive shaft lip seal. The procedure is quite simple, and all necessary parts are provided in [this](#) Service Kit 710023.

If your motor unit already has these drain holes, it already has a water trap fitted and you may use the basic Service Kit 710022 instead of this one if you wish.

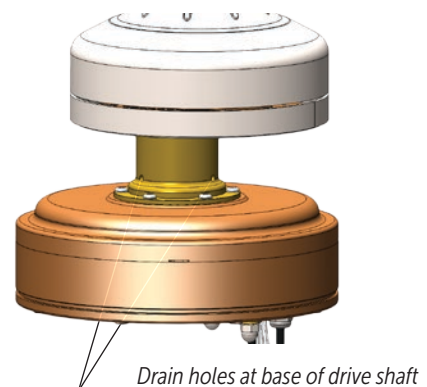

Service Kit Contents



RD100169

823100

536000

RD100066

821802

821801

RD100074

Please take a moment to familiarise yourself with the contents of the RA710023 service kit.

- | | |
|--|--|
| ① RD100169 Lip Seal 30mm x 37mm x 4mm | ⑥ 821802 Upper Cone |
| ② 823100 Glide Bushing 34mm OD x 30mm ID | ⑦ 2x RD100066 NBR O-ring 30mm OD x \varnothing 1.5mm |
| ③ 2x ISO7380-A4-M6X12mm Screw | ⑧ 821801 Lower Cone |
| ④ 990299 Thread-lock | ⑨ 2x RD100074 NBR O-ring 54mm OD x \varnothing 1.5mm |
| ⑤ 536000 Spacer 40mm OD x 30mm ID | ⑩ 980700 Klüber Isoflex® TOPAS NB52 Grease |

Isoflex® is a registered trademark of Klüber Lubrication München SE & Co. KG

Optional Items: (recommended - may be ordered separately)



Part no. RD738000
Pin Spanner



Part no. 821810
Mounting tool for Lip Seal



Part no. RA500001-1
Andersen Winch Grease

Other items that you will need:

- Circlip pliers or small flat screwdriver for removal of circlip on drive gear
- Small flat screwdriver for removal of old lip seal
- Pin spanner for removal of clamping ring
- Allen key for removal of M6 button-head screws securing shaft housing flange to gearbox
- Soft cloth or paper towels
- Andersen Winch Grease (may be ordered separately if you don't already have it on board).
- Small brush for grease
- Mineral spirits (white spirits) for cleaning and degreasing. Do not use alcohol or other solvents for cleaning.

Getting Started

1. AFTER DISCONNECTING POWER, remove the winch drum to access the mounting screws and remove the winch from the stainless steel deck plate – if in doubt, see the service manual for your winch (available for download from our website at andersenwinches.com).
2. Disconnect all wiring connections from the motor.

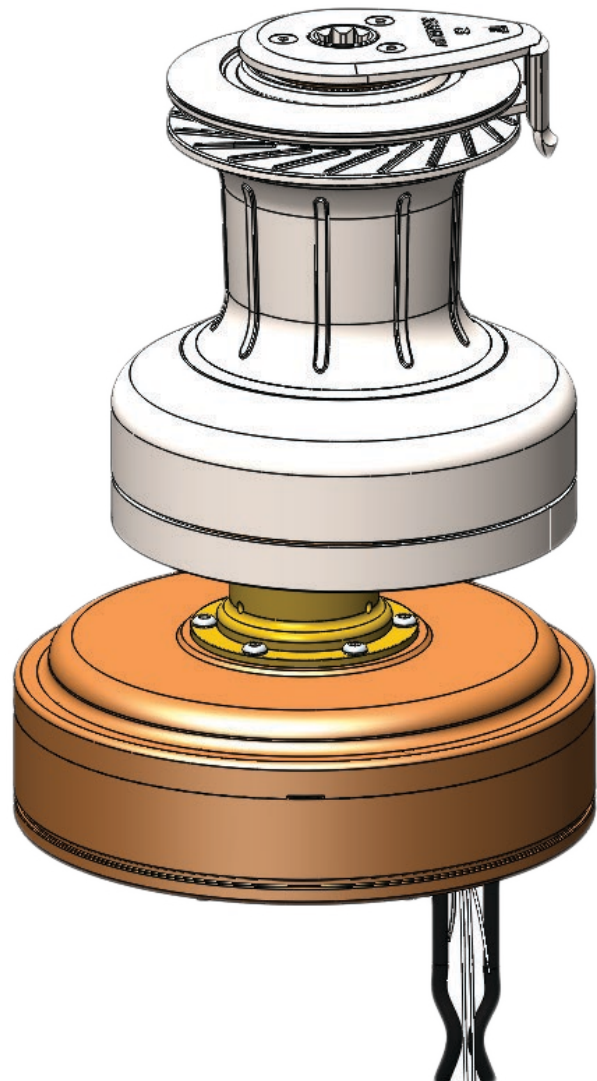

STEP 1

Remove the motor unit.

Using a circlip pliers or small flat screwdriver, remove the circlip and lift the drive gear off the drive shaft. Then use an allen key to remove the anti-rotation grub screw that locks the clamping ring in position. While supporting the motor/gearbox unit from below, use a pin spanner to unscrew and remove the clamping ring. Now remove the motor/gearbox unit from underneath, leaving the stainless steel deck plate in place on the deck.

**STEP 2**

Remove the Drive Shaft and Housing.

Use an allen key to remove the 6x M6 button-head screws that secure the drive shaft housing to the top of the gearbox. Then lift the drive shaft housing to remove it, together with the driveshaft.

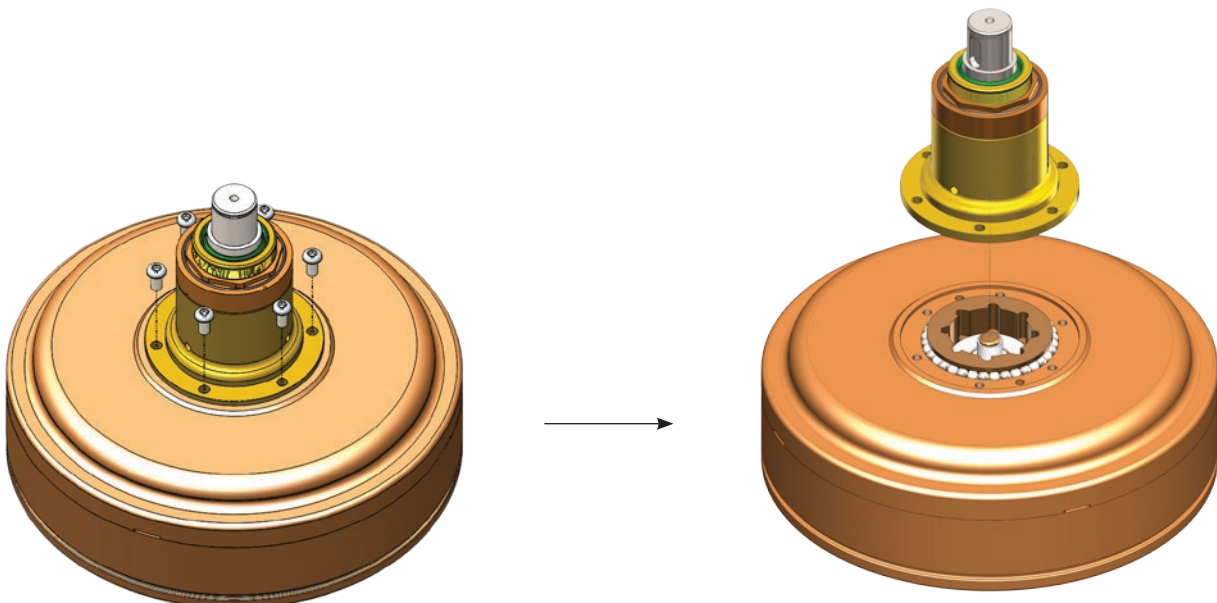

STEP 3

Remove glide bushing and lip seal.

Place the housing on a workbench and remove the old lip seal by prying it out with the help of a screwdriver, taking care not to scratch or gouge the metal surface around it. The seal will be damaged/destroyed during this operation and can not be re-used. Clean the recess in the housing thoroughly after removing the old lip seal.

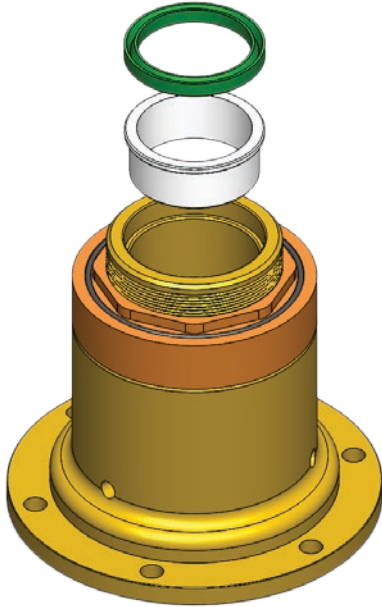

With the housing upside down and supported in a vice or on a pair of blocks with clearance underneath, use a flat screw driver and a soft hammer to tap the glide bushing out.

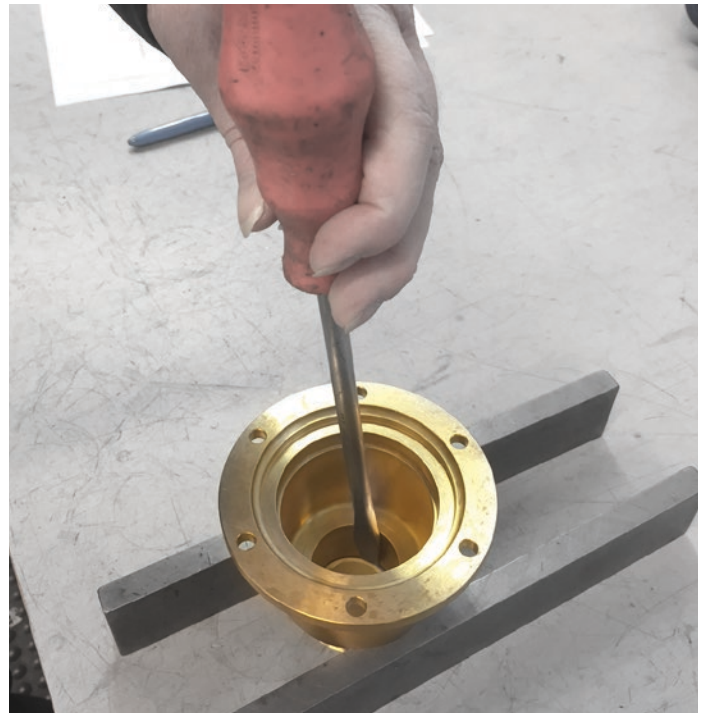

STEP 4

Drill holes in drive shaft housing for drainage.

Drill three 5mm diameter holes at a distance of 18 - 25 mm from the bottom surface of the lower flange, evenly spaced at 120° around the shaft housing.

Remove any burrs and clean thoroughly to remove any metal particles.

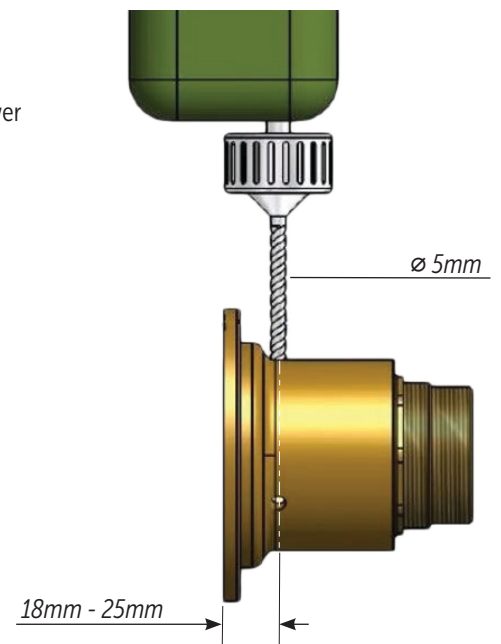
**STEP 5**

Clean and degrease drive shaft housing.

Clean and degrease the inside of the housing, taking particular care to remove all grease and residue from the recess where the lip seal will be inserted. Use only mineral spirits (white spirits) for degreasing – do not use alcohol, kerosene or other solvents.

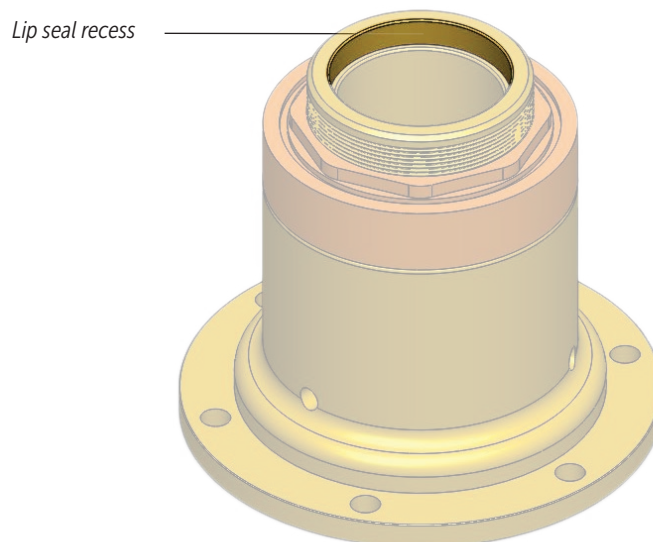

STEP 6

Fit new glide bushing, lip seal and O-ring.

Do not use any grease during this step. Locate the new glide bushing (part number 823100), lip seal (part number RD100169) and O-ring (part number RD100074) provided in the Service Kit. The optional mounting tool, part number 821810, can be used to help fit the glide bushing and lip seal.

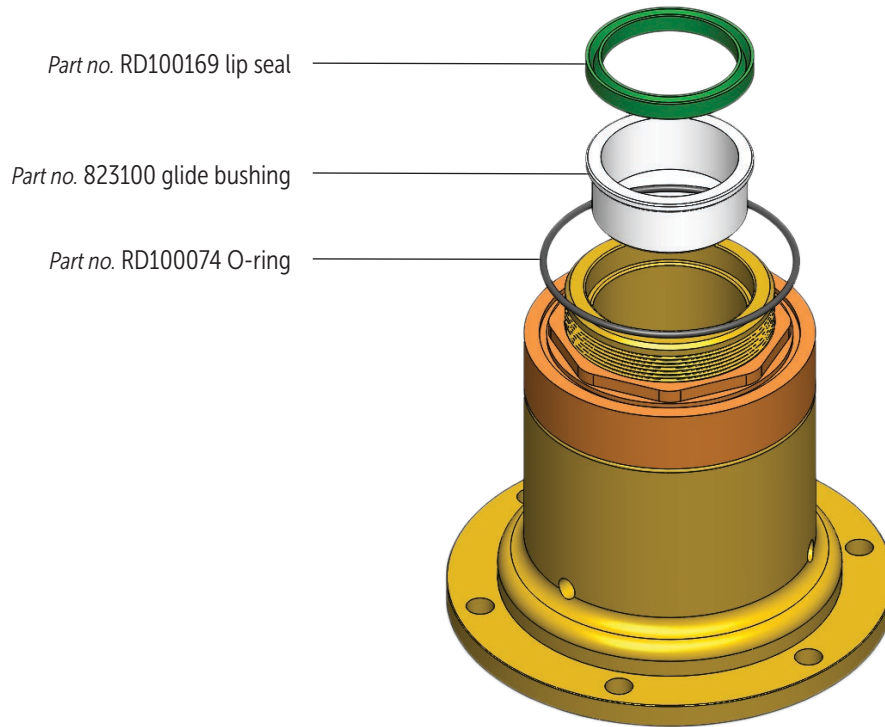

Push the glide bushing (Part no. 823100) into place from the top of the housing – tap gently with a soft hammer if necessary to seat it firmly. The mounting tool 821810 may be used to assist.



STEP 6 continued

Align the lip seal accurately with the recess at the top of the drive shaft housing, with the open groove facing up, and gently press the lip seal completely into the recess so that it remains perfectly flush with the top of the housing. If the seal does not remain securely in position, or pops back up again, remove and clean the recess more thoroughly before attempting again.

If using the optional mounting tool 821810, check which end of the tool has the correct diameter to fit your lip seal. Place the new lip seal onto that end of the tool, with the open groove facing up, then use the tool to insert the seal in the recess. The end of the tool will fit in the hole, accurately aligning the seal as it is inserted. Tap with the help of a soft hammer to fit the seal perfectly and completely into position, flush with the top surface of the drive shaft housing.



Remove the old O-ring from the recess at the top of the drive shaft housing, and use a cloth to remove any dirt or residue. Locate the new O-ring, part number RD100074 (provided in the Service Kit), and place it in the recess.

STEP 7

Fit the water trap on the drive shaft.

Locate the water trap components and the TOPAS NB52 grease in the Service Kit.

1. Fit the O-ring RD100074 in the recess on the outer base of the Lower Cone, part number 821801.
2. Fit the 2x O-rings RD100066 in the recesses provided inside the Upper Cone, part number 821802.
3. Apply TOPAS NB52 grease liberally to all three O-rings.
4. Slide the Lower Cone 821801, the Upper Cone 821802, and the Spacer 536000 onto the drive shaft in the correct sequence as shown in the diagram, using a small screwdriver to help the O-rings in the Upper Cone slide onto the shaft.

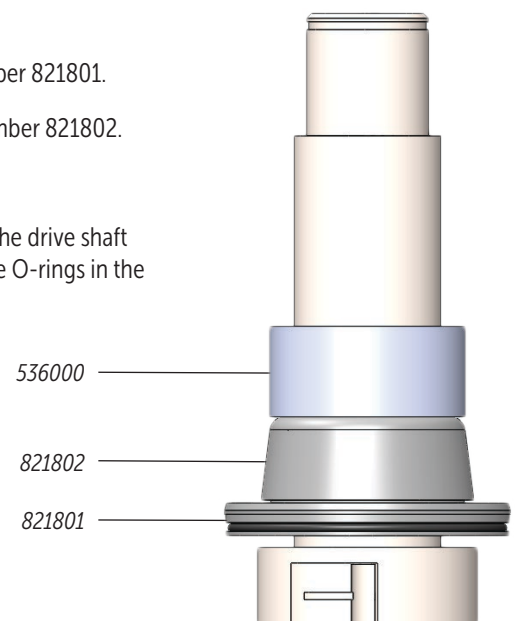

STEP 8

Grease the drive shaft and fit the drive shaft housing.

Grease the drive shaft with TOPAS NB52 grease, especially the part where it will pass through the lip seal, and fit the drive shaft into the housing. Clean the pawls in the base of the drive shaft and lubricate with Andersen Winch Grease (do not use TOPAS NB52 grease on the pawls).

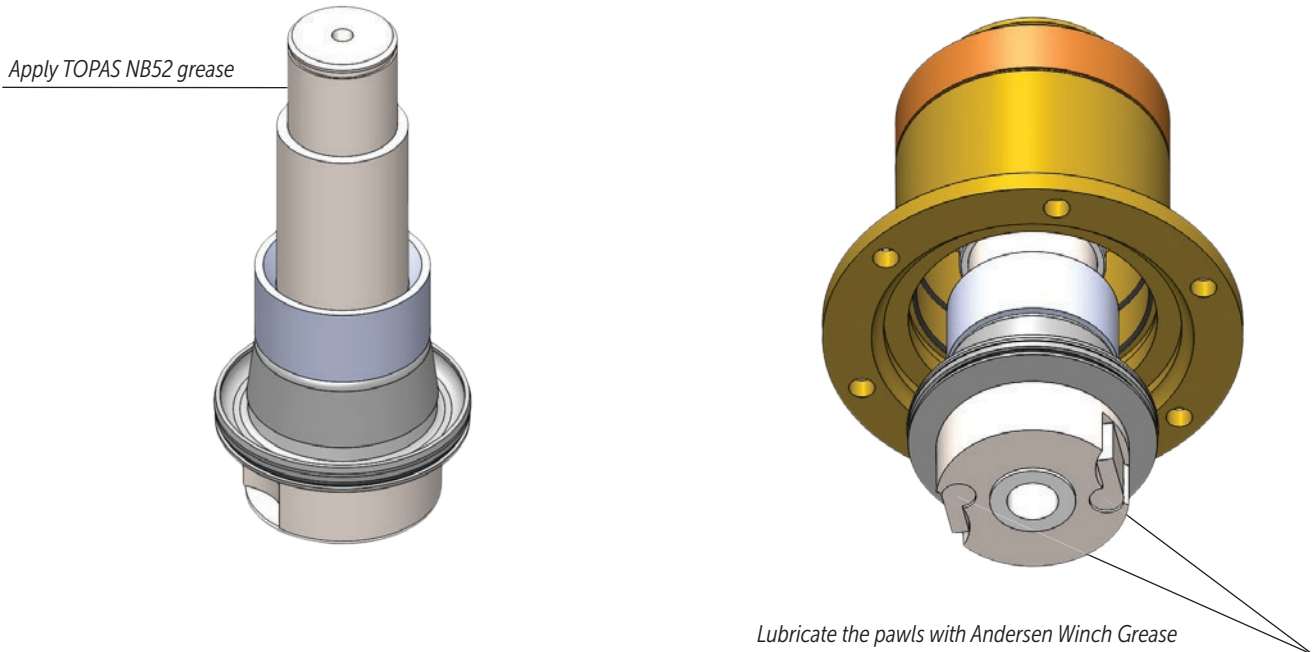

STEP 9

Clean and lubricate the ball bearings.

The ball bearings may be serviced without disassembling the gearbox. Wipe away surface dirt and grease using a cloth and some mineral spirits (white spirits) - do not use alcohol, kerosene or other solvents for degreasing. After cleaning, use a small brush to apply Andersen Winch Grease liberally to the ball bearings and adjacent surfaces.

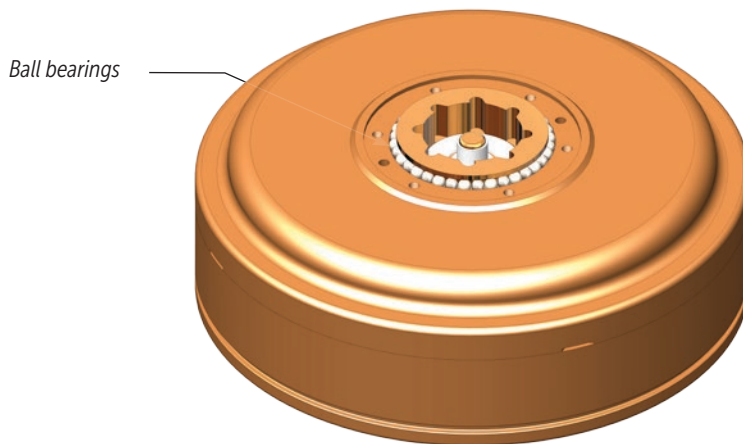

STEP 10

Reassemble drive shaft and housing.

Place the drive shaft and housing in position, align the fastener holes and secure the assembly with the 6x M6 button-head screws. Use a drop of thread-lock, part number 990299 (provided in the Service Kit), on each screw. Two spare screws are provided in the Service Kit, in case any have been lost.



STEP 11

Grease lip seal and top O-ring, install motor unit.

Apply plenty of TOPAS NB52 grease to the lip seal, and apply a thin coat of the same grease to the O-ring.

Raise the motor into position from below deck and secure with the clamping ring – remember to insert and tighten the small grub screw to lock the clamping ring. Then fit the drive gear and secure with the circlip.

Liberally apply grease to lip seal



Apply a coat of grease to O-ring

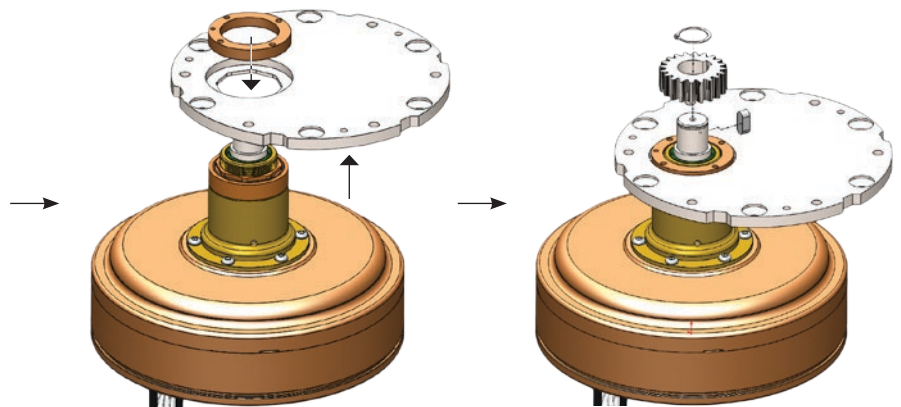

STEP 12

Connect power and check operation.

Connect switches and power cables, taking care to maintain correct polarity. **Note: incorrect connection of power cables will permanently damage the motor.** See the Compact Motor™ Electric Winch User Manual for further information (available for download from our website at andersenwinches.com).

Connect power to the motor and test by running at half speed for a few seconds. The motor and gearbox operation should be smooth and quiet.



Safety First! Disconnect power from the motor again before proceeding to the next step.

STEP 13

Re-install winch.

Re-install the winch on the deck plate.

- Test the winch by spinning the drum by hand and operating the winch manually with a handle. The winch should operate smoothly in both gears.
- Connect power to the motor and test the winch with no rope and no load. It should operate smoothly.

Congratulations! You have completed an important maintenance procedure, and your Compact electric winch is now ready to deliver many more seasons of enjoyable sailing.

Contact

Andersen Stainless Steel Winches® are manufactured by Ronstan Denmark ApS.

Jægervænget 36
7100 Vejle
Denmark

www.andersenwinches.com
info@andersenwinches.com