

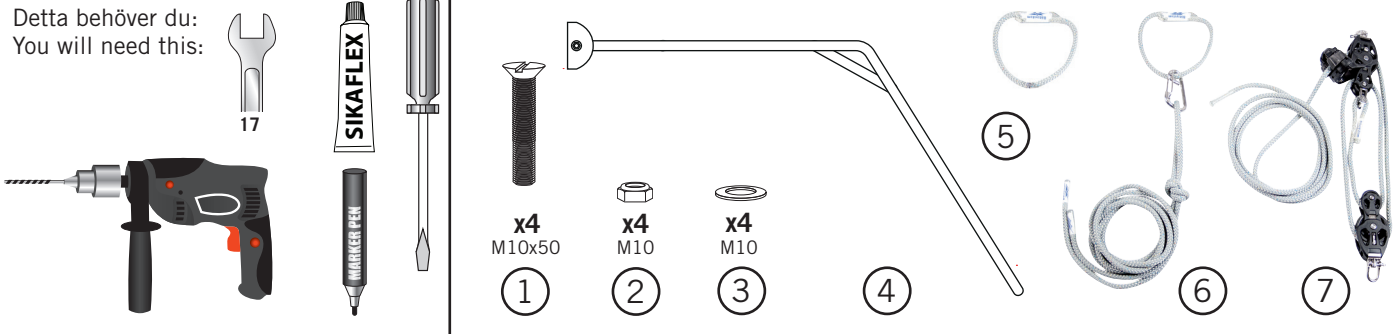

Detta behöver du:
 You will need this:



2xDV25: 2x50 kg

2xDV32: 2x100 kg

2xDV42: 2x150 kg

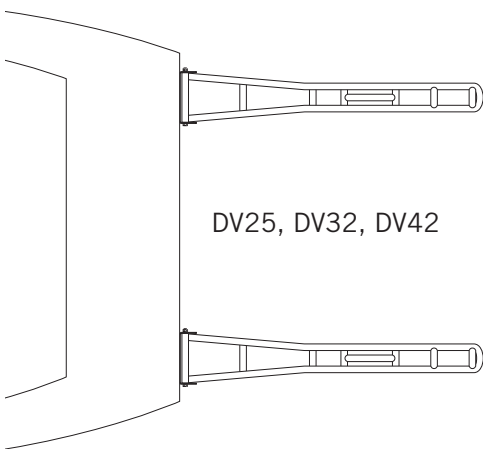

DV25, DV32, DV42

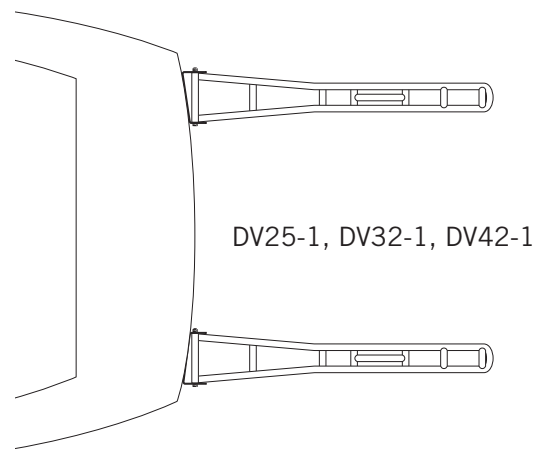

DV25-1, DV32-1, DV42-1

Rak akterspegel
 Straight aft

Böjd akterspegel
 Curved aft

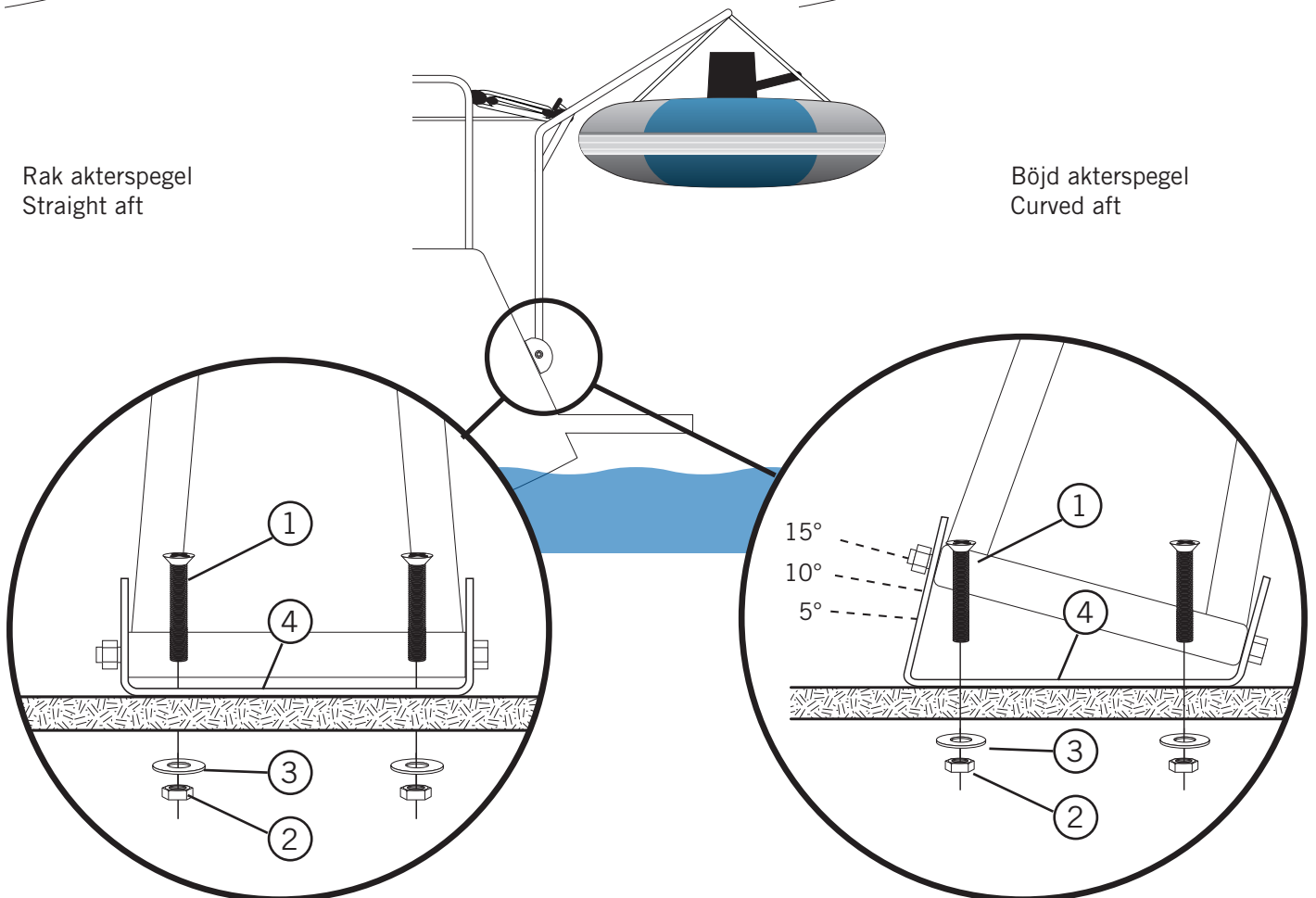

Dävert Monteringsanvisning

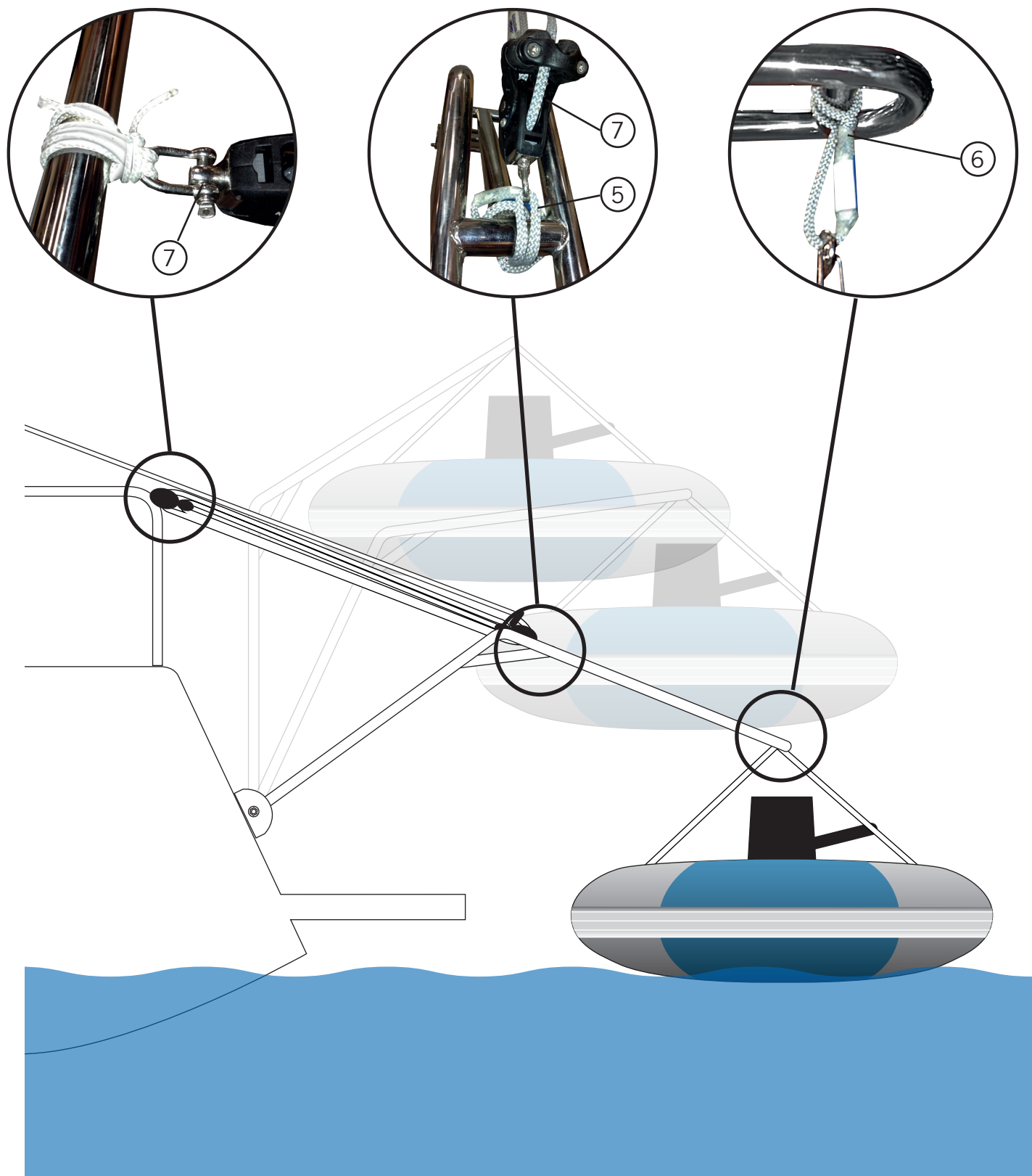

Dävert Monteringsanvisning

Rekommenderad vinkel på block och linor / The preferred angle of blocks and ropes

Blockets fästvinkel bör vara horisontell eller uppåt mot båten

Block bracket should be horizontal or upward toward the boat

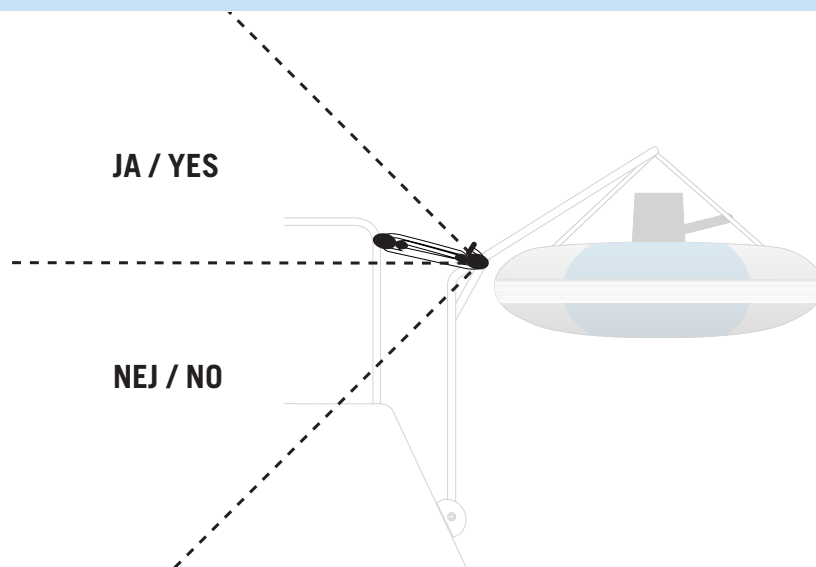

Rekommenderade fästpunkter för block / Recommended mounting points for block

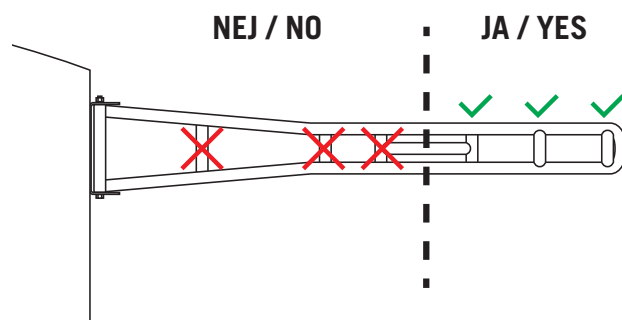
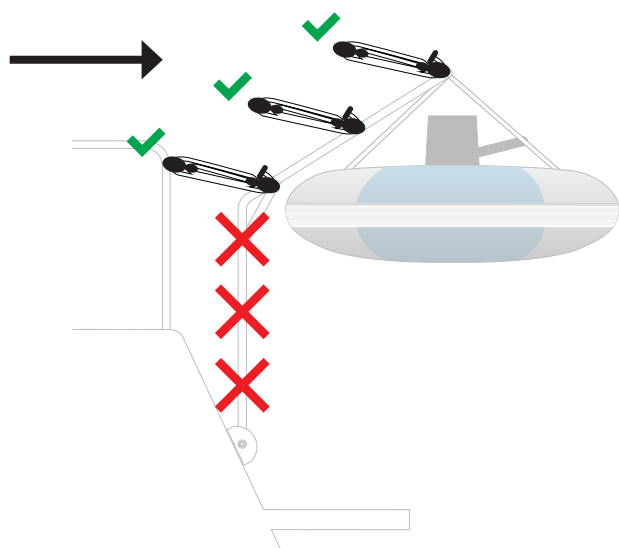

Fäst blocken ovanför dävertens böj
Attach the blocks above the davit bend

Rekommenderad viktfordelning för varje dävert / The preferred weight distribution for each davit

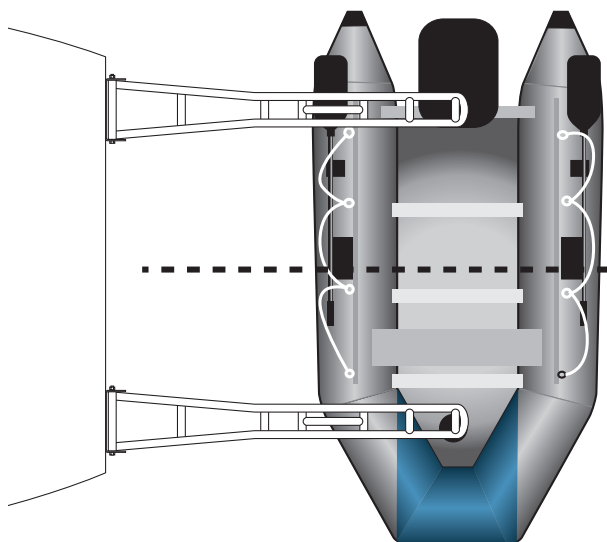

Max vikt, dävert 1 / Max load, dinghy 1 (Halv båt + motor / Half boat + motor)

DV25: Max 50 kg
DV32: Max 100 kg
DV42: Max 150 kg

Max vikt, dävert 2 / Max load, dinghy 2 (Halv båt / Half boat)

DV25: Max 50 kg
DV32: Max 100 kg
DV42: Max 150 kg

Transportläge / Transport mode

Säkra jollen med korslagda linor och säkra mot båten enligt bilden

Secure the dinghy with crossed ropes and secure with the boat as shown

